



Anforderungen erfüllt nach

DIN-EN 1527

-	6	2	0	-	0	-	1	3
---	---	---	---	---	---	---	---	---

GW

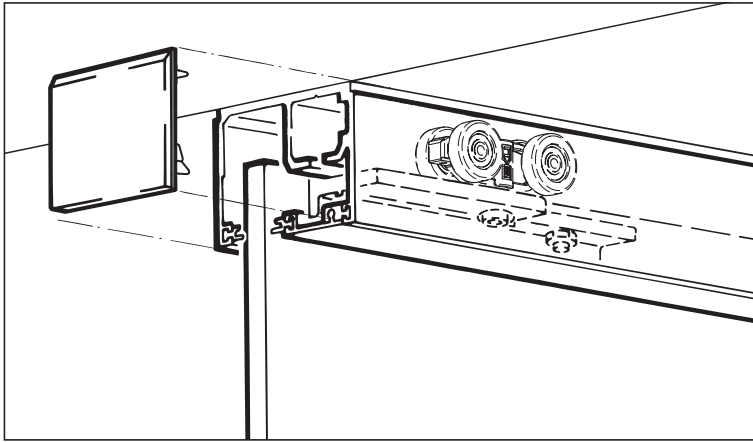

Garnituren / Sets / Garnitures

1 Türe Door Porte		No. 057.3091.071	
2x	2x	2x	
1x	1x	1x	1x
1x	1x	12x	
1x	1x		1x

GW

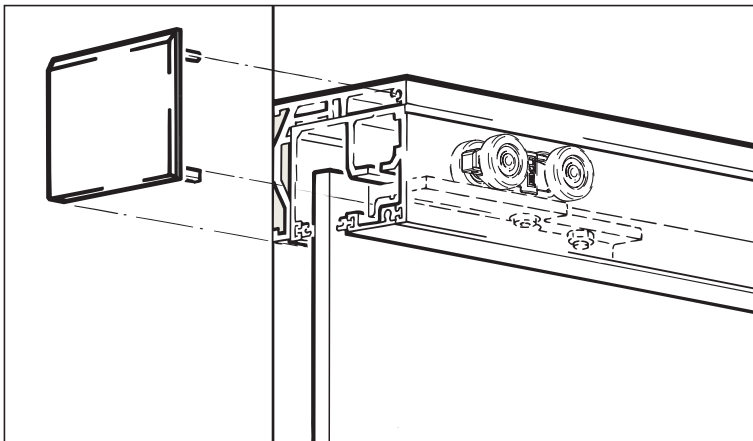

GWF

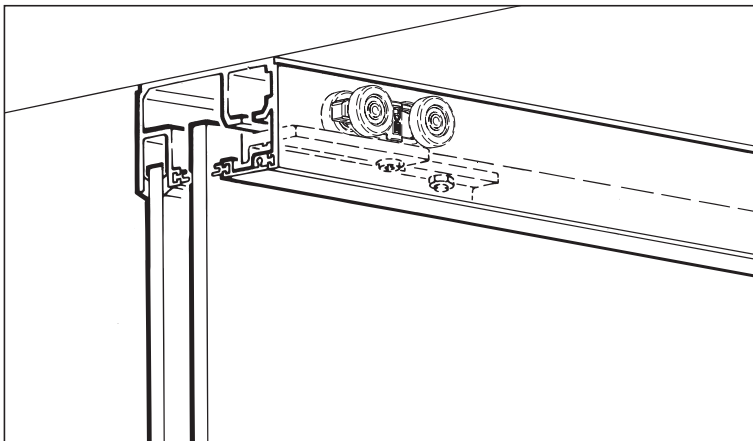

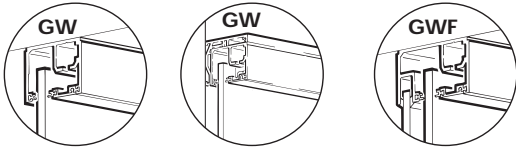

Zubehör / Accessories / Accessoires

Laufschiene Alu, eloxiert, gelocht

Running track aluminium, anodized, pre-drilled
 Rail de roulement en alu, anodisé, perforé

Gr./Size	Art. No.
2500 mm	057.3083.250
3500 mm	057.3083.350
6000 mm	057.3083.600

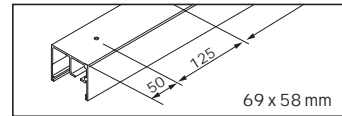

Endkappen-Set zu 057.3083, Kunststoff anthrazit

End cap set for 057.3083, plastic anthracite
 Jeu d'embouts pour 057.3083, plastique anthracite

1x	057.3118.071
----	--------------

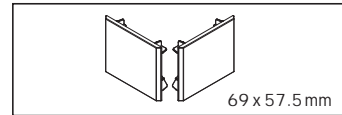

Wandbefestigungs-Winkelprofil, EKU PORTA 100 GW, Alu eloxiert, gelocht

Wall mounting angle profile, EKU PORTA 100 GW, alu anodized, pre-drilled

Profil en équerre pour fixation murale, EKU PORTA 100 GW, alu anodisé, perforé

2500 mm	057.3100.250
3500 mm	057.3100.350
6000 mm	057.3100.600

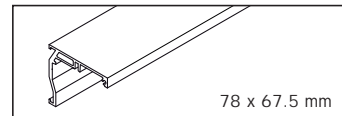

Endkappen-Set zu 057.3100, Kunststoff anthrazit, mit Schrauben für Schiene bis 2500 mm

End cap set for 057.3100, plastic anthracite, inkl. screws for tracks up to 2500 mm
 Jeu d'embouts pour 057.3100, plastique anthracite, incl. vis pour rail jusqu'à 2500 mm

1x	057.3103.071
----	--------------

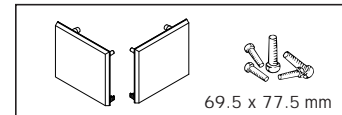

Laufschiene Festglas, Alu, eloxiert, gelocht

Running track fixed glass, aluminium, anodized, pre-drilled
 Rail de roulement vitre fixe, en alu, anodisé, perforé

2500 mm	057.3084.250
3500 mm	057.3084.350
6000 mm	057.3084.600

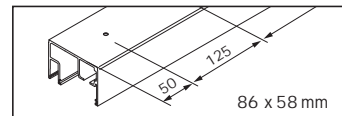

Blendenprofil, Alu, eloxiert

Fascia profile aluminium, anodized
 Profil de cache en alu, anodisé

2500 mm	057.3085.250
3500 mm	057.3085.350
6000 mm	057.3085.600



Stirnprofil, Alu, eloxiert, zu 057.3084

Front edge profile, aluminium, anodized, for 057.3084
 Profil à l'avant, en alu, anodisé, pour 057.3084

2500 mm	042.3005.250
3000 mm	042.3005.300
6000 mm	042.3005.600

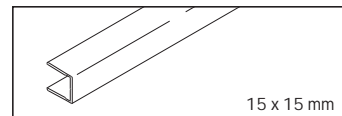

U-Führungsschiene, Alu, eloxiert, gelocht

U-shaped guide track aluminium, anodized, pre-drilled
 Rail de guidage en U en alu, anodisé, perforé

2500 mm	057.3056.250
3500 mm	057.3056.350
6000 mm	057.3056.600

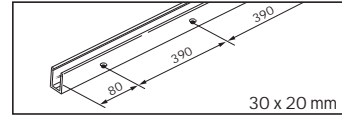

Befestigungs-Set zu Festglashalteprofil / U-Führungsschiene

Fixing set for fixed glass support profile / U-shaped guide track
 Jeu de fixation pour porte-vitre fixe / guidage en U

1x	057.3076.071
----	--------------

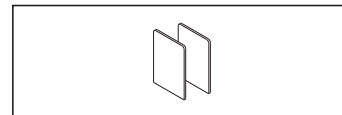

Dichtungsprofil, Kunststoff schwarz, in Rollen

Sealing profile, plastic black, in coils
 Profil d'étanchéité en rouleaux, plastique noire

20 m	057.3072.001
------	--------------

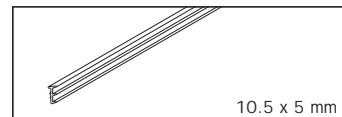

Sichtschutzdichtung, Kunststoff schwarz, in Rollen

Screening seal, black plastic, in rolls
 Joint pare-vue, plastique noir, en rouleaux

20 m	057.3078.002
------	--------------

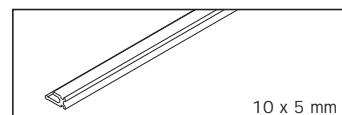

Schrauben-Set zu 057.3100 > 2500mm

Screw set for 057.3100 > 2500 mm
 Jeu de vis pour 057.3100 > 2500 mm

12x	057.3102.071
-----	--------------

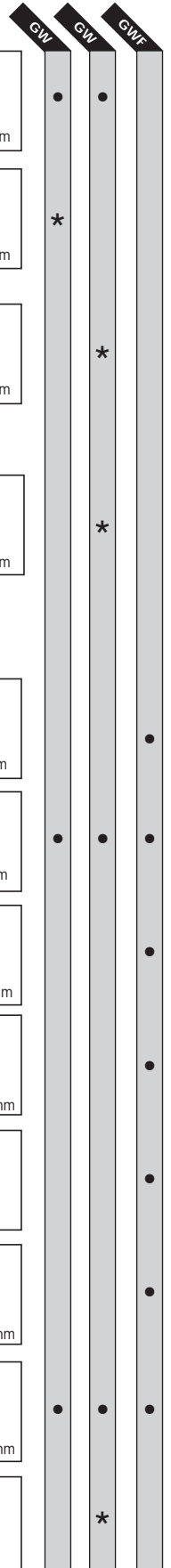
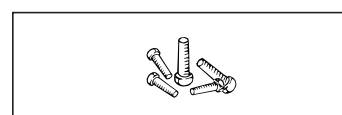

*optional

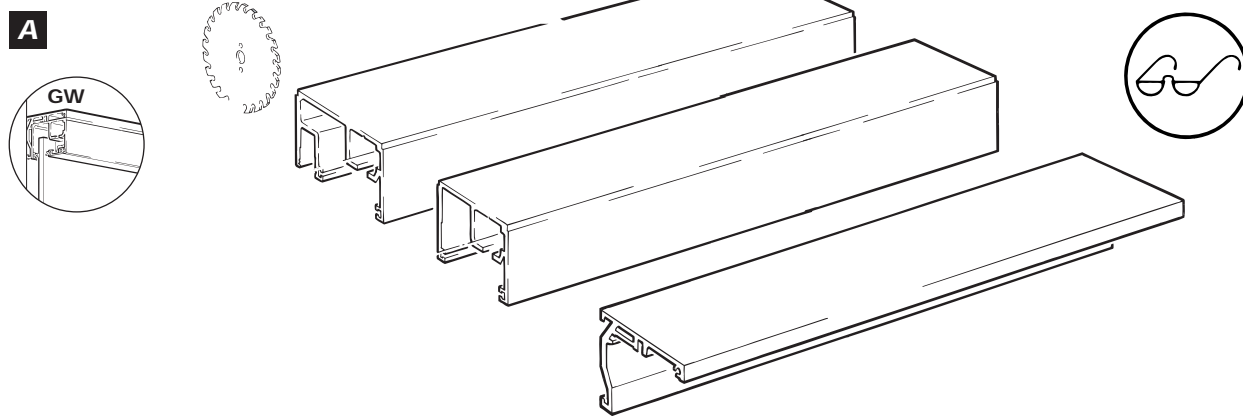
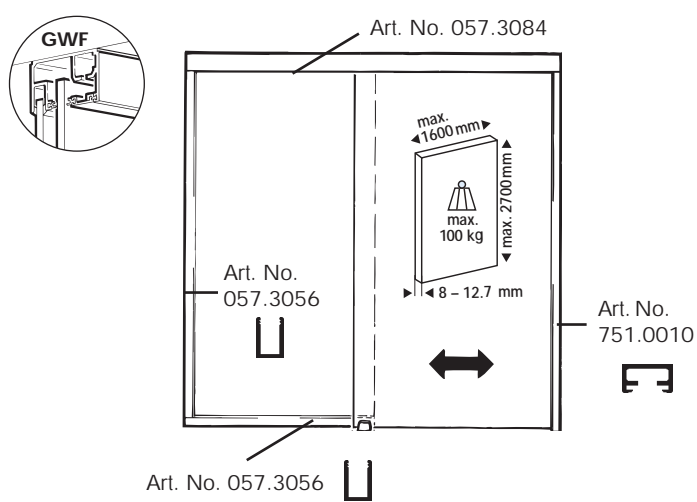
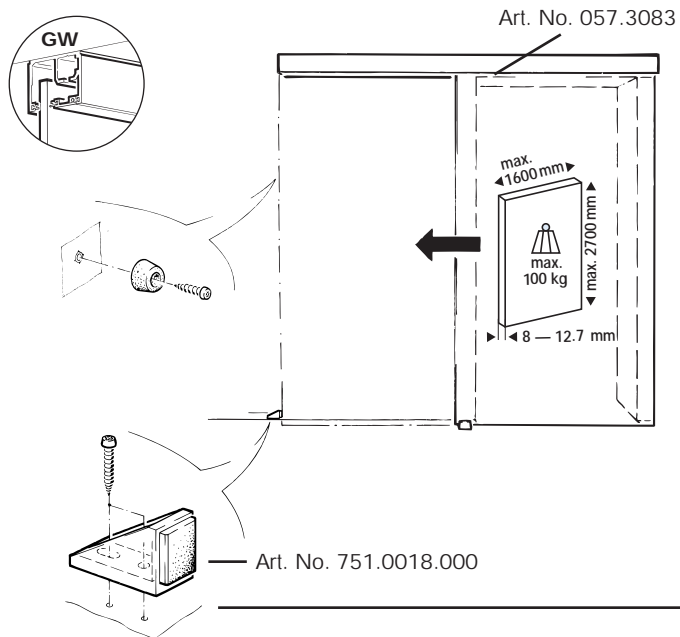

B  **EKU PORTA** 100 GW | GWF Synchro

Siehe Montageanleitung
See mounting instructions
Voir Instructions de montage
Art. No. 788.2000.156

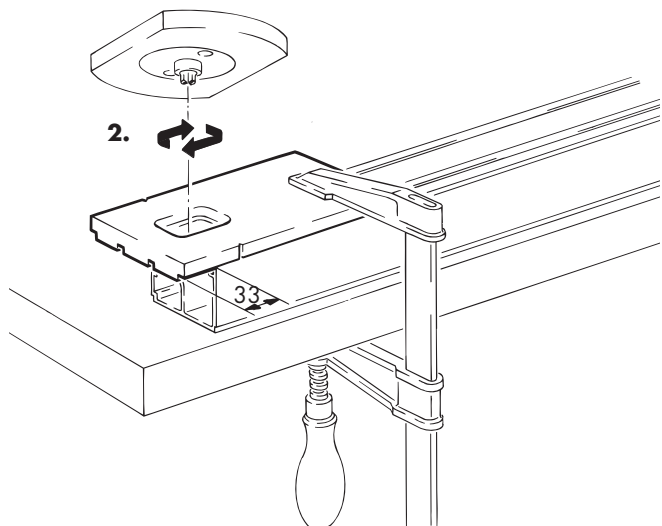
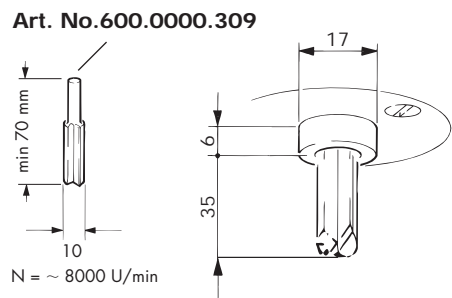
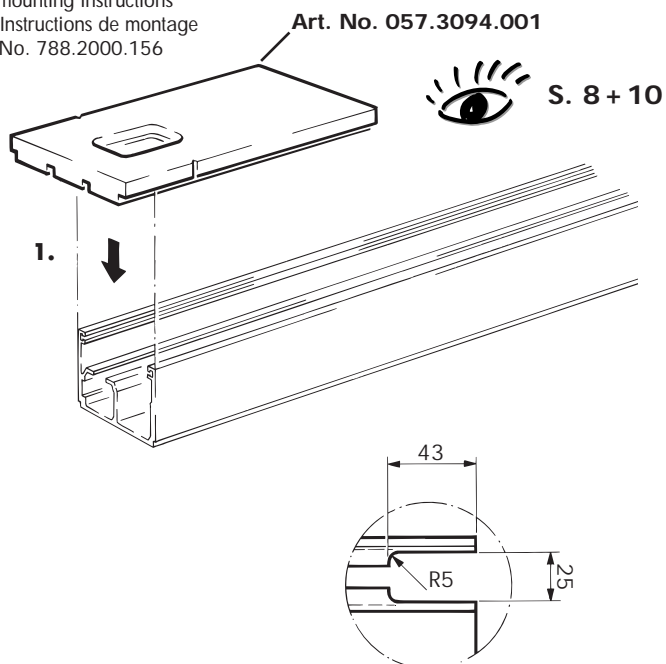

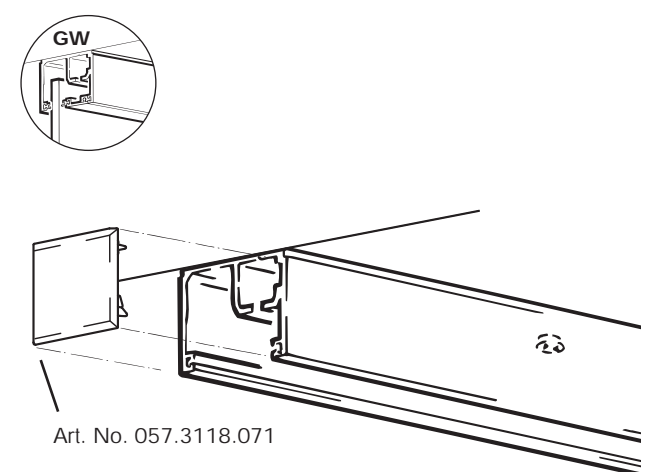
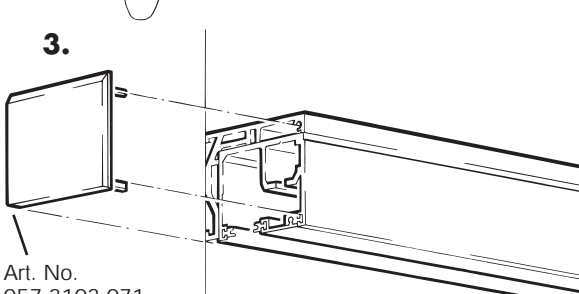
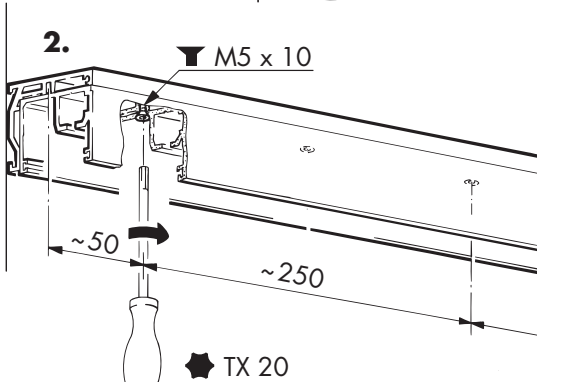
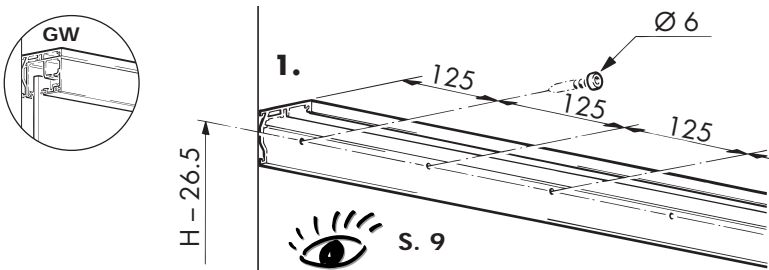
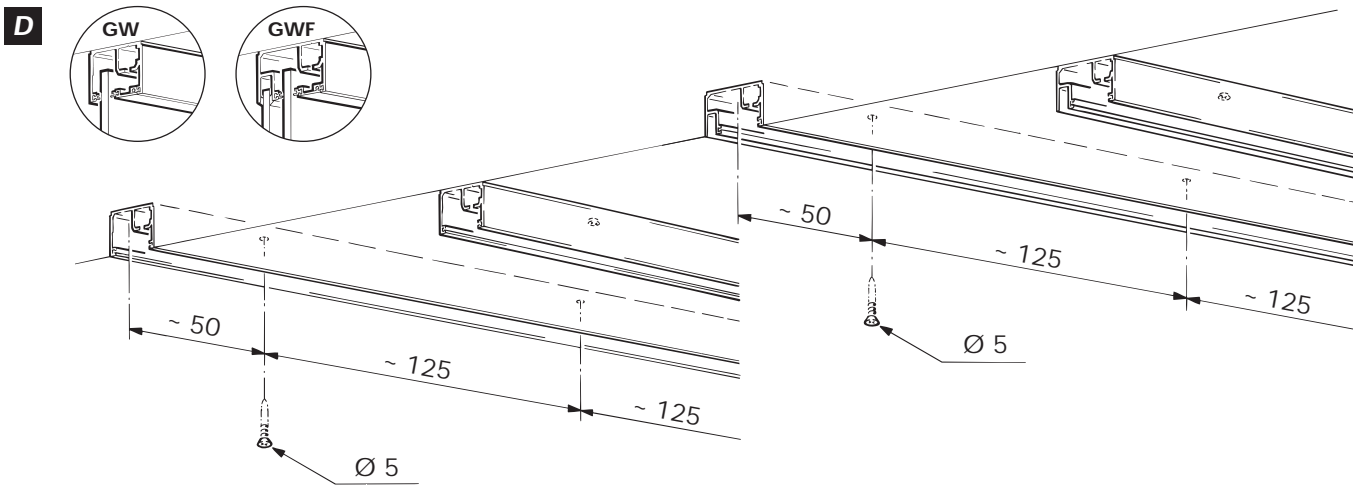
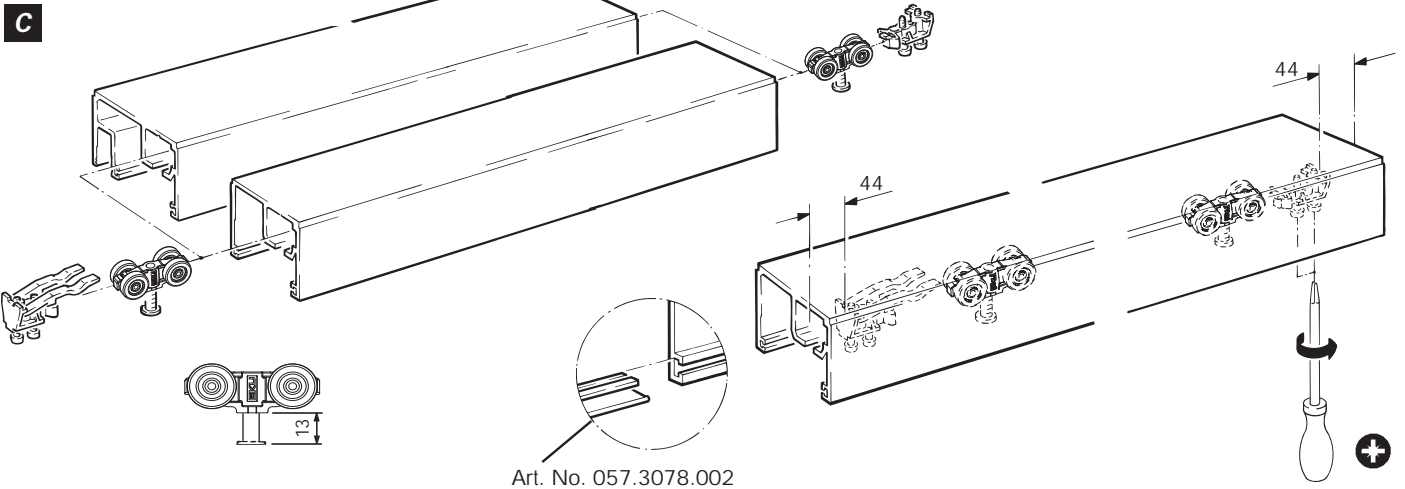

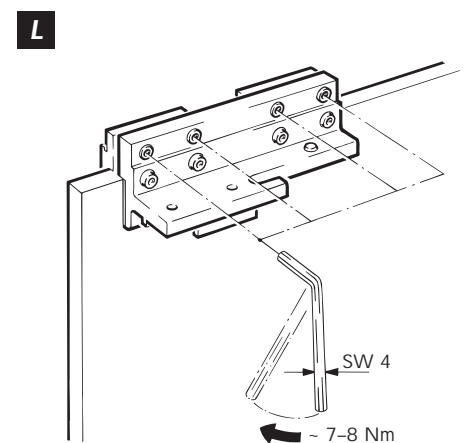
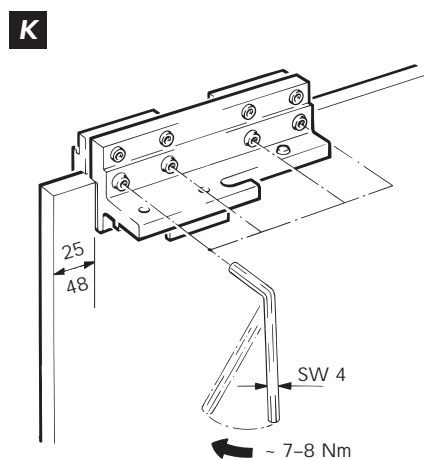
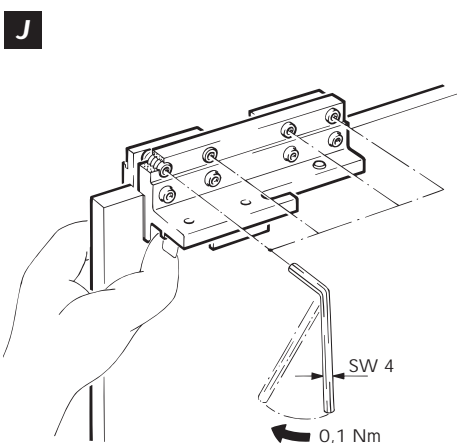
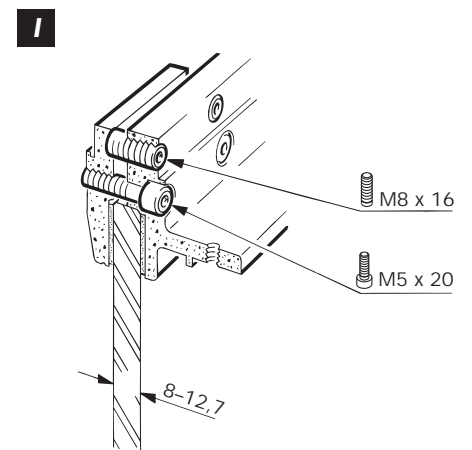
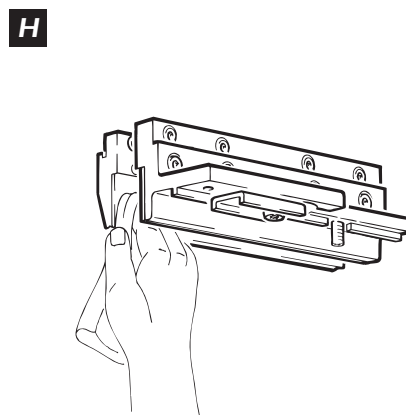
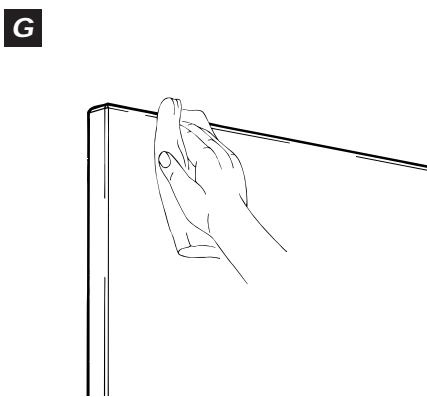
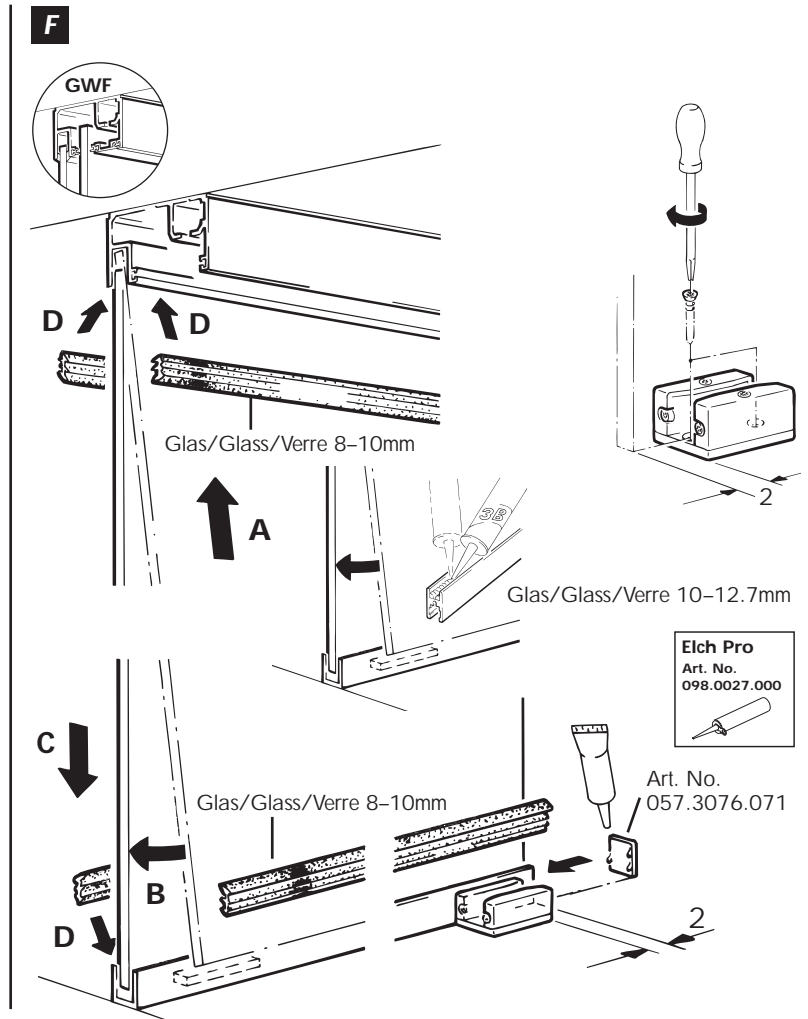
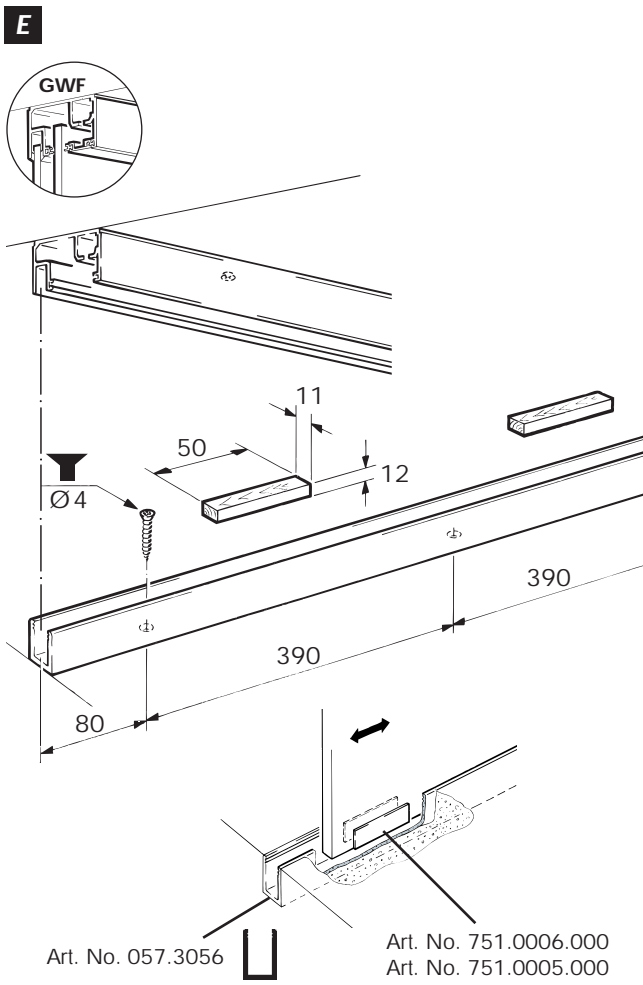

M

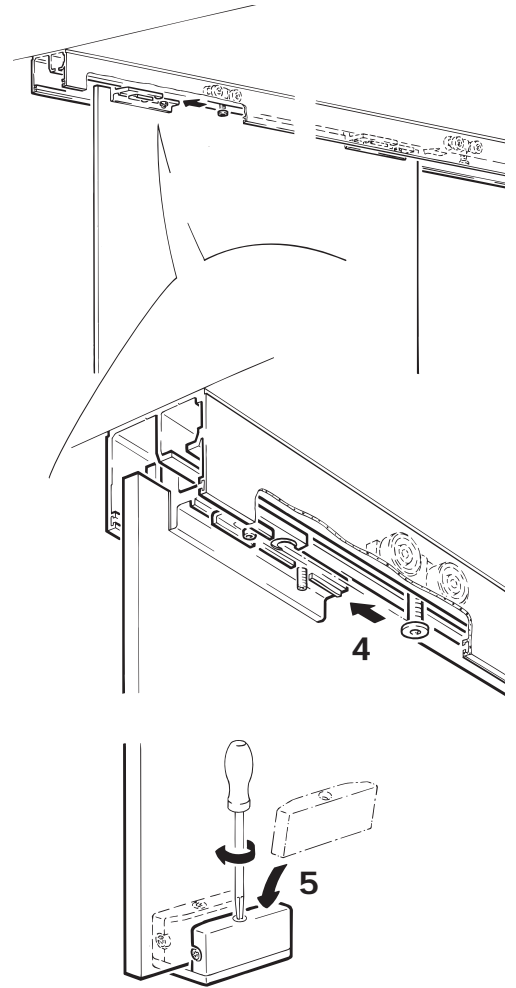
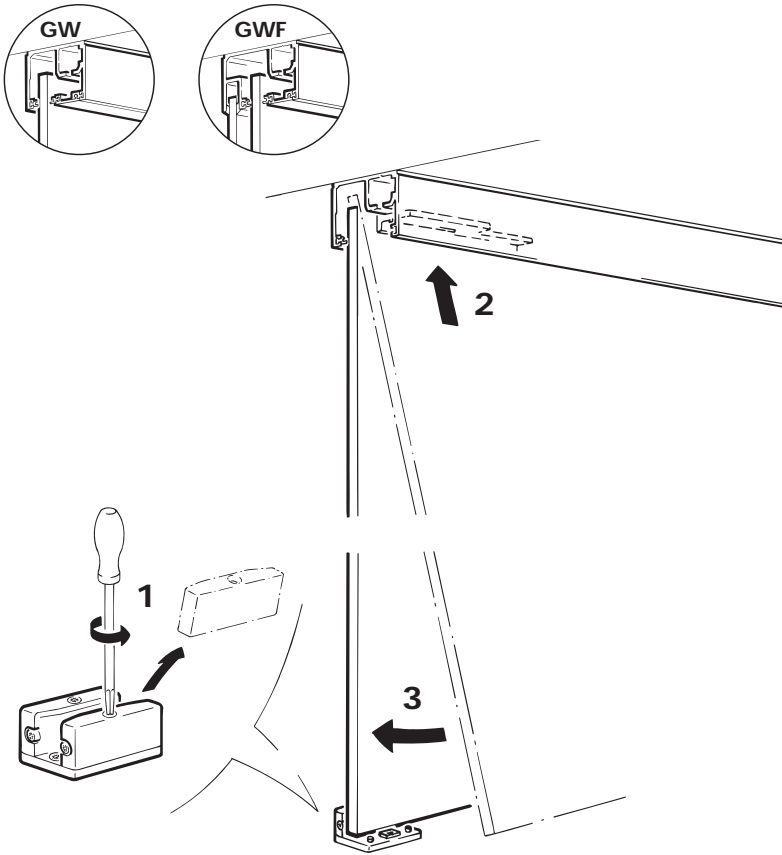

N

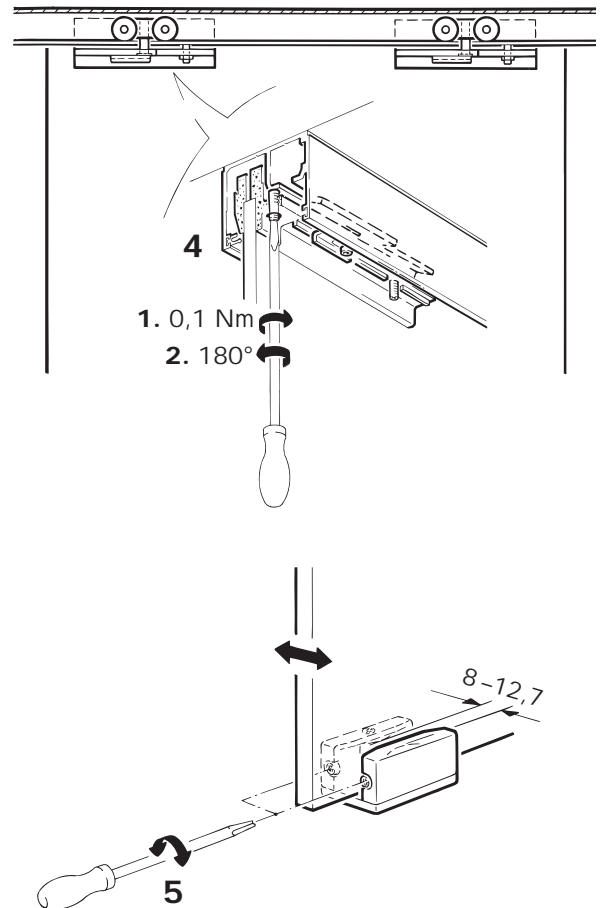
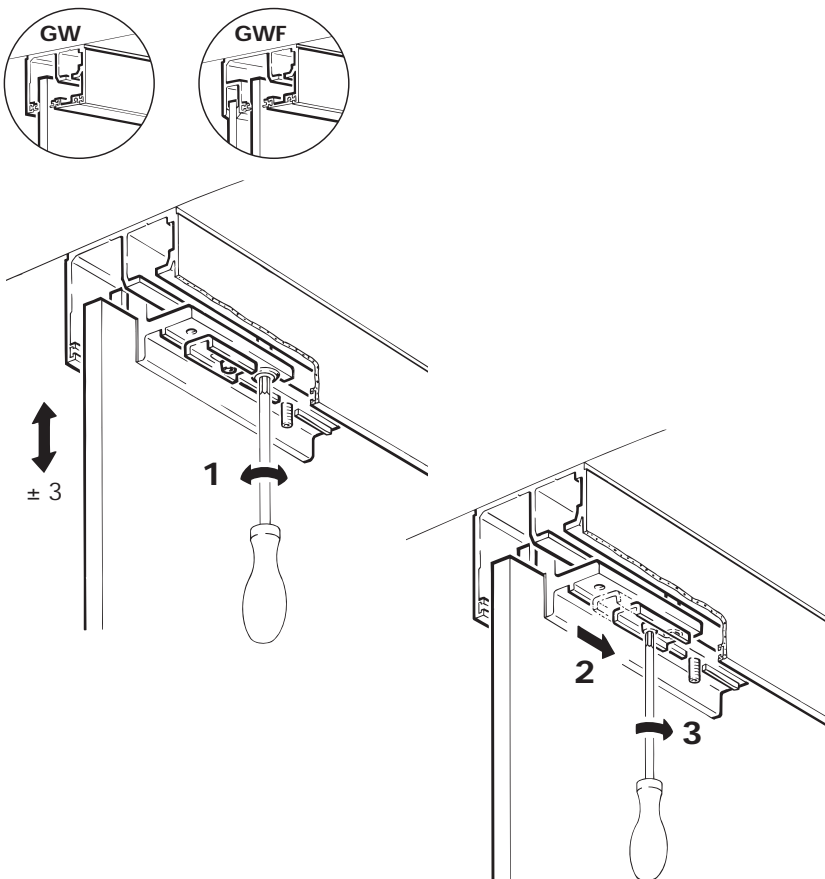

O

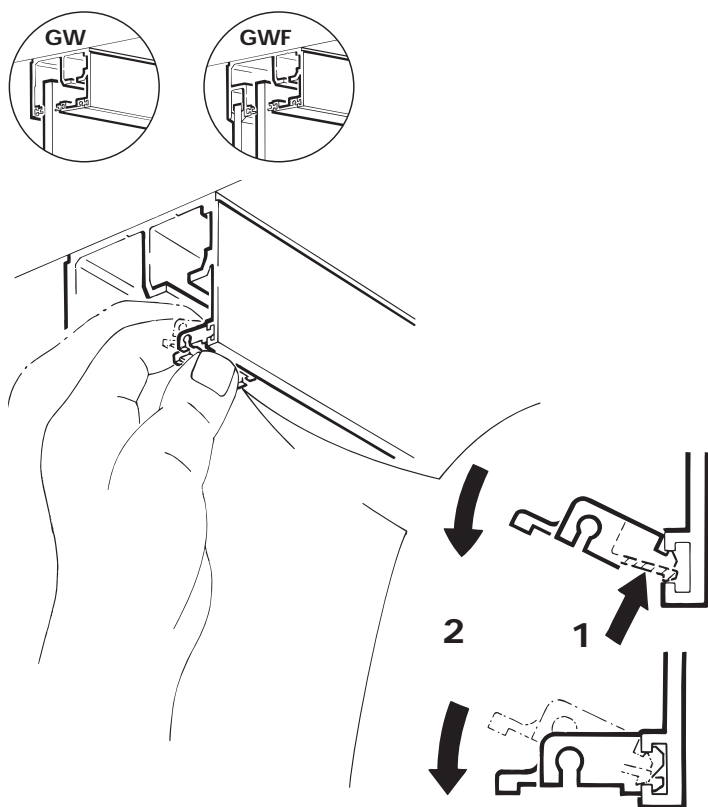

P

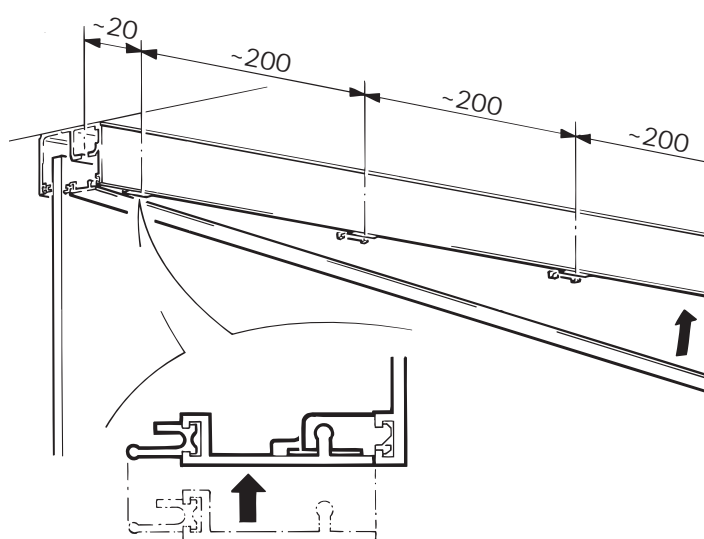

Q

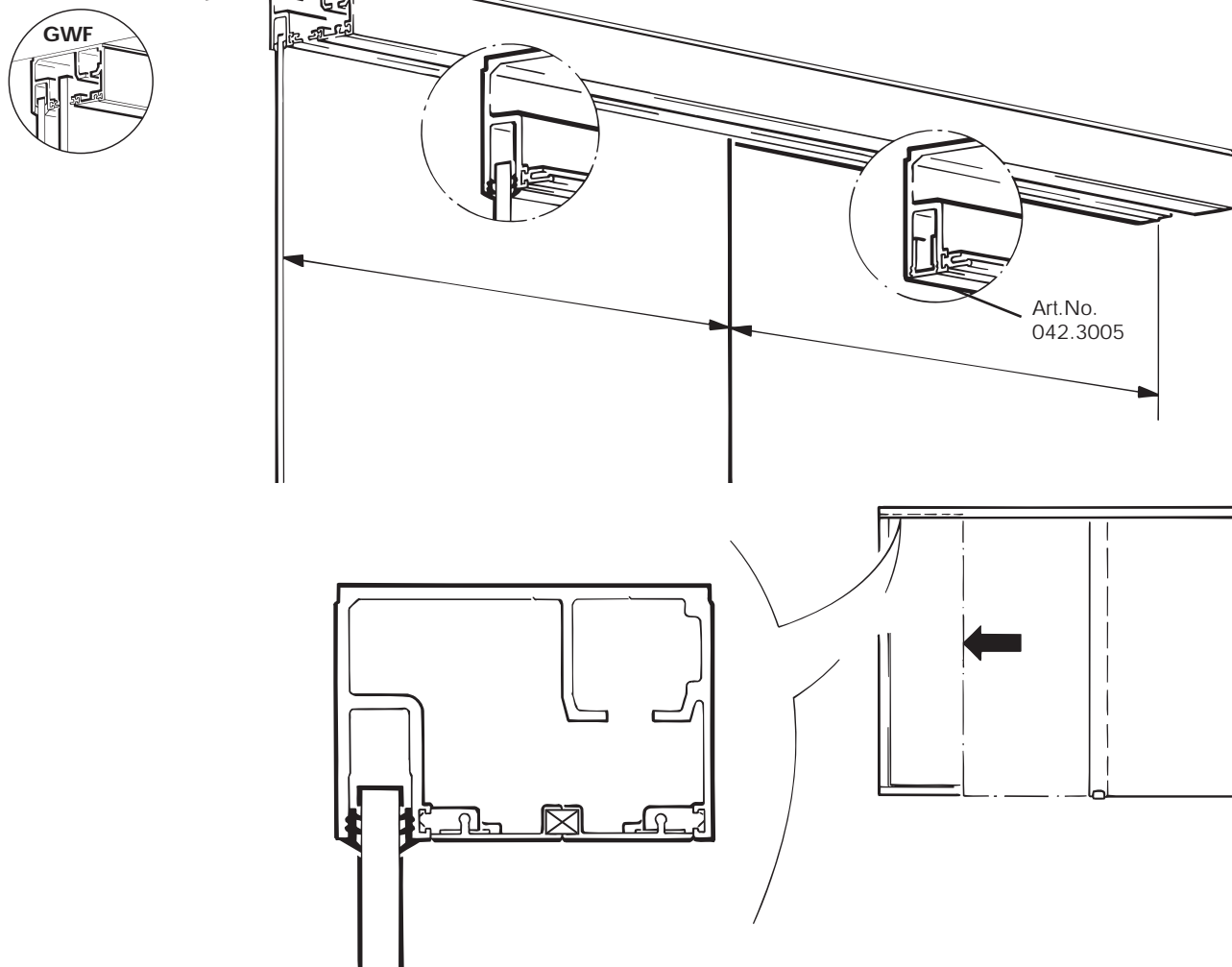

GW

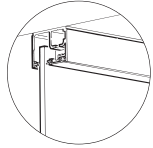

Einbaubeispiele / Mounting examples / Exemples de montage

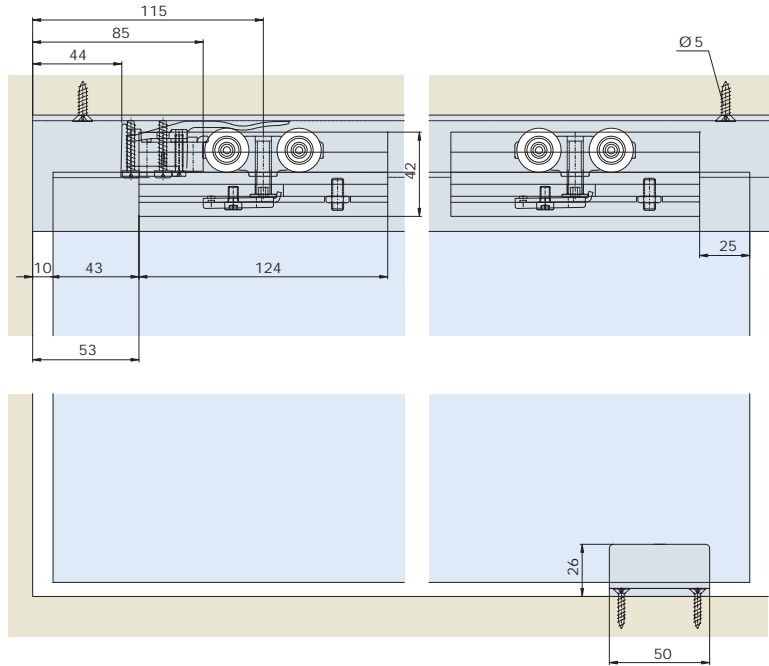
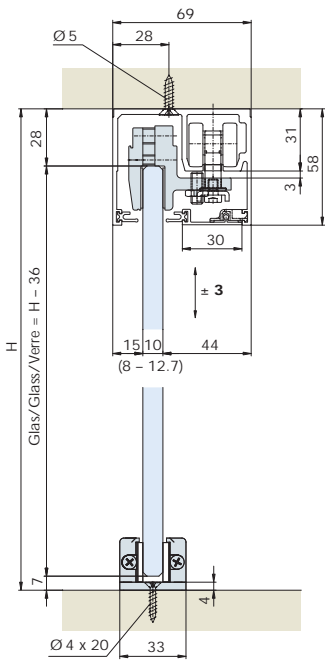

Einbaubeispiel deckenbündige Montage

Mounting example flush with the ceiling
Exemple de montage affleurant avec le plafond

GW

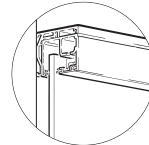

Einbaubeispiele / Mounting examples / Exemples de montage

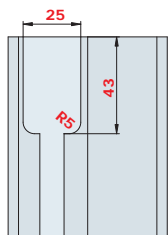
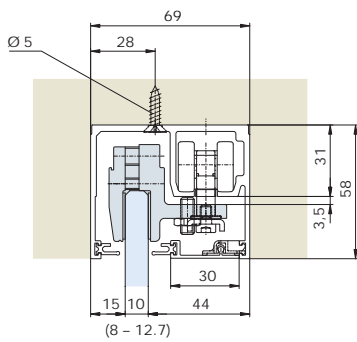

Ausfräsung zum Ein-/Ausfahren Laufwerk und Stopper
Recess for sliding running gear and stop in and out
Encoche pour introduire/sortir le chariot et la butée

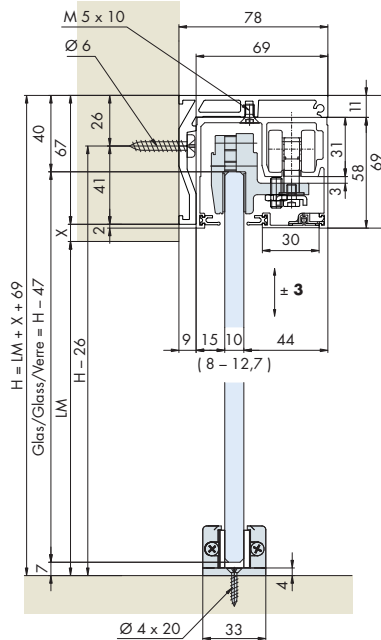

GWF

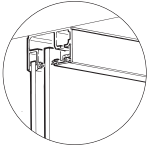

Einbaubeispiele / Mounting examples / Exemples de montage

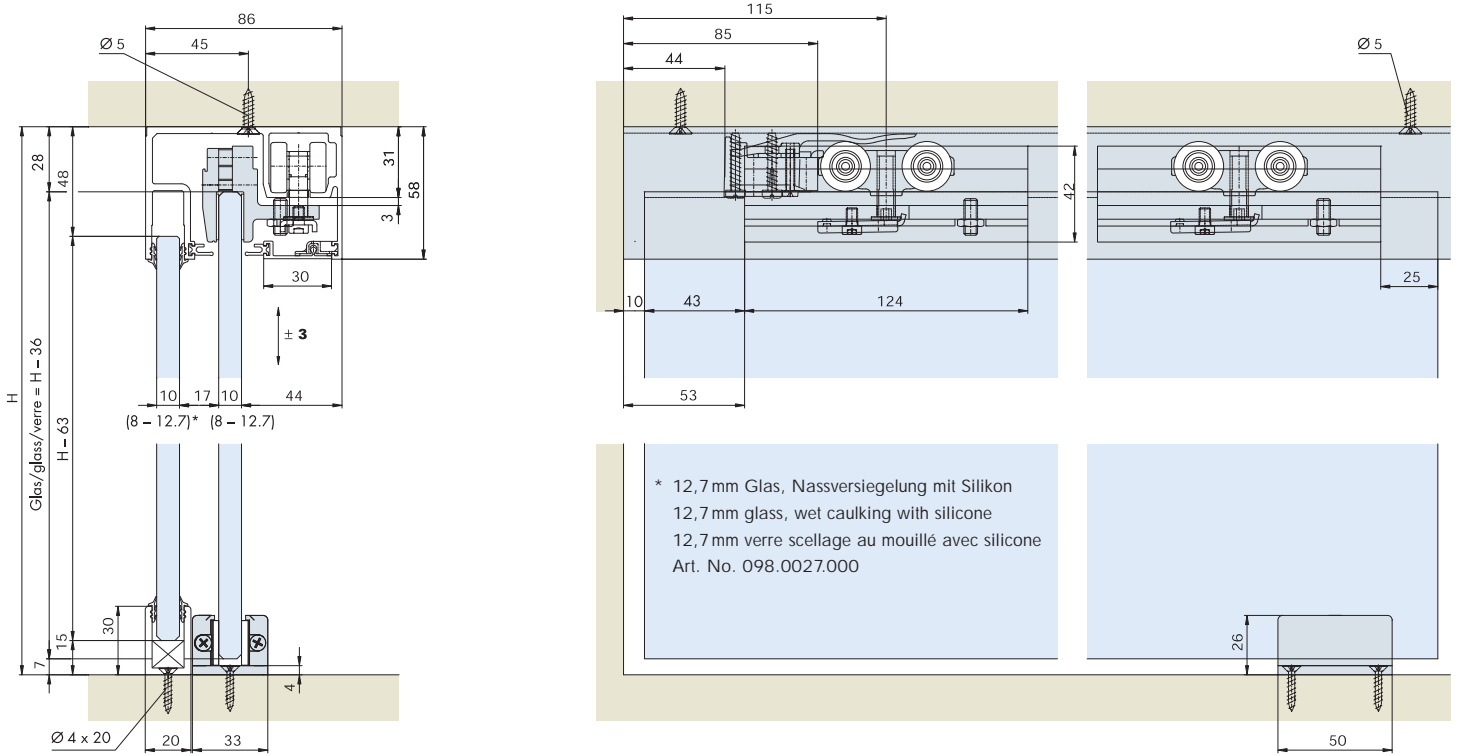

Einbaubeispiel deckenbündig

Mounting example flush with the ceiling

Exemple de montage affleurant avec le plafond

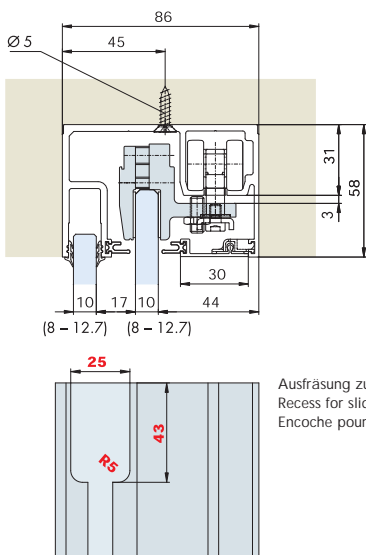

Ausfräsung zum Ein-/Ausfahren Laufwerk und Stopper
 Recess for sliding running gear and stop in and out
 Encoche pour introduire/sortir le chariot et la butée